



3D Adapter

MODEL

3DC-1000

OWNER'S GUIDE

For questions:

- Visit our website at www.mitsubishi-tv.com.
- E-mail us at MDEAservice@mdea.com.
- Call Consumer Relations at 800-332-2119 for operational or connection assistance.

To order replacement or additional remote controls or other accessories, visit our website at www.mitsuparts.com or call 800-553-7278.

Important Safety Instructions

- 1) Read these instructions.
- 2) Keep these instructions.
- 3) Heed all warnings.
- 4) Follow all instructions.
- 5) Do not use this apparatus near water.
- 6) Clean only with dry cloth.
- 7) Do not install near any heat sources such as radiators, heat registers, stoves, or other apparatus (including amplifiers) that produce heat.
- 8) Only use attachments/accessories specified by the manufacturer.
- 9) Refer all servicing to qualified service personnel. Servicing is required when the apparatus has been damaged in any way, such as power-supply cord or plug is damaged, liquid has been spilled or objects have fallen into the apparatus, the apparatus has been exposed to rain or moisture, does not operate normally, or has been dropped.

FCC Information

Product: 3D Adapter
 Model: 3DC-1000
 Responsible Party: Mitsubishi Digital Electronics America, Inc.
 9351 Jeronimo Rd.
 Irvine, CA
 92618-1904

NOTE: This equipment has been tested and found to comply with the limits for a Class B digital device, pursuant to Part 15 of the FCC Rules. These limits are designed to provide reasonable protection against harmful interference in a residential installation. This equipment generates, uses and can radiate radio frequency energy and, if not installed and used in accordance with the instructions, may cause harmful interference to radio communi-

cations. However, there is no guarantee that interference will not occur in a particular installation. If this equipment does cause harmful interference to radio or television reception, which can be determined by turning the equipment off and on, the user is encouraged to try to correct the interference by one or more of the following measures:

- Reorient or relocate the receiving antenna.
- Increase the separation between the equipment and receiver.
- Connect the equipment into an outlet on a circuit different from that to which the receiver is connected.
- Consult the dealer or an experienced radio/TV technician for help.

WARNING. To reduce the risk of fire or electric shock, do not expose this apparatus to rain or moisture.

Please check www.mitsubishi-tv.com for updates on 3D signals and safety.

Features

- Converts 3D video originating in several popular formats to checker-board format for display on your 3D or 3D-ready Mitsubishi television.
- Processes side-by-side, top-and-bottom, and frame-packing 3D (e.g., Blu-ray 3D) formats.
- Passes 2D images unaltered for normal display.
- Includes two pairs of active-shutter 3D glasses and matching IR emitter.

Compatible with these Mitsubishi television models:

3D-Ready Televisions (2007 through 2010)	833 series (2007) C8 series (2008) 735 series (2008) 736 series (2008) 835 series (2008)	L65-A90 (2008) 737 series (2009) 837 series (2009) C9 series (2009) L75-A81 (2010)	L75-A91 (2010) 638 series (2010) C10 series (2010)
3D Televisions (starting in 2010)	738 series (2010)	838 series (2010)	

The Mitsubishi 3D Adapter, Model 3DC-1000, may be used to display 3D content only when connected to a Mitsubishi 3D Ready TV or a Mitsubishi 3D TV. A 3D source device coupled with the Mitsubishi 3D Adapter is required to support display of 3D games, 3D broadcasts from terrestrial/cable/satellite and 3D Blu-ray disc content.

Lithium Battery Safety

This product uses CR2025 Li/MnO₂ lithium coin batteries.

WARNING: Lithium coin cell batteries pose a serious risk of injury if ingested. Keep cells out of reach of children. If ingested immediately contact a physician or the National Poison Center at 202-625-3333.

CAUTION: Danger of explosion if battery is incorrectly replaced. Replace only with the same or equivalent type (CR2025).

CAUTION: Risk of fire and burns. Do not recharge, disassemble, heat above 100° C (212° F), or incinerate. Keep battery out of reach of children.

Disposal. Dispose of used batteries promptly according to local recycling or waste regulations.

For assistance call 1(800) 332-2119

3D Adapter

Battery Installation

The remote control requires one CR2025 lithium battery.

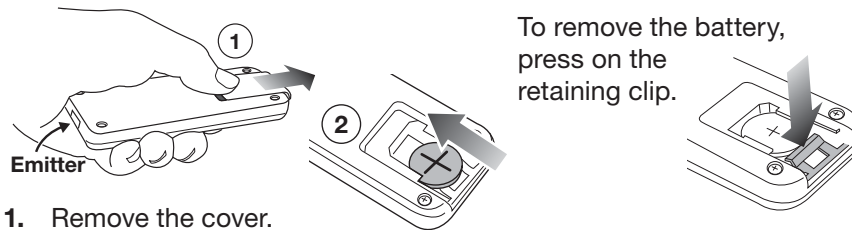

1. Remove the cover.
2. Insert the battery, positive side up. Be sure the retaining clip holds the battery securely.
3. Reinstall the cover.

Controls and Indicators

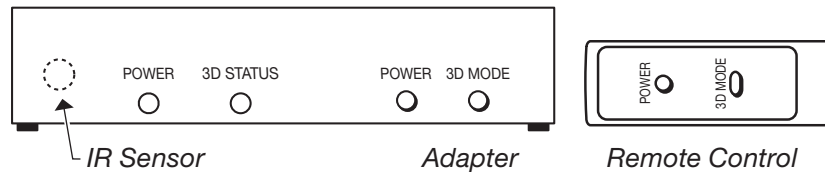

POWER Light	Lit when power is on.
3D STATUS Light	Lit during 3D signal processing.
POWER Button	Allows manual override of auto on/off. Press to power off the Adapter if it powers on when not needed,
3D MODE Button	Allows manual selection of 3D format conversion.

Please check www.mitsubishi-tv.com for updates on 3D signals and safety.

Connecting the Adapter

Connecting a Single 3D Video Source

- Power off all devices prior to connecting the Adapter.
- If the device was in use prior to adding the Adapter, use the same TV input if possible.
- On an 833 series TV, the input must be named **Game**.

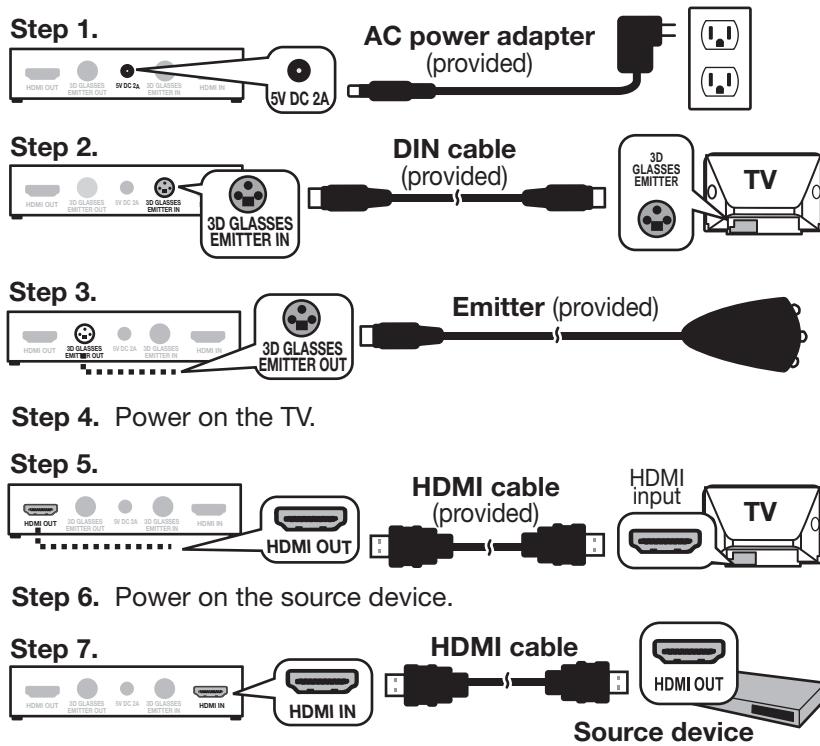

Connecting Multiple 3D Video Sources

- Connect devices with checkerboard output directly to the TV. Enable checkerboard output from the devices if needed.
- If using a newer A/V receiver, you may be able to connect devices to the A/V receiver as shown below. The A/V receiver must support HDMI 1.4 and 3D video capabilities.

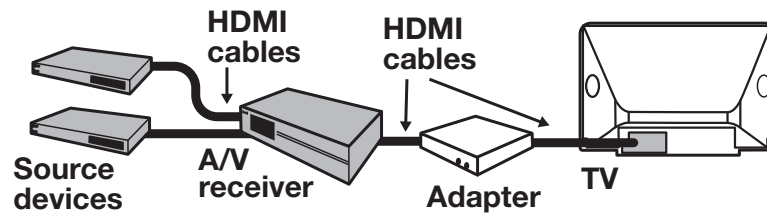

For assistance call 1(800) 332-2119

Using the Adapter

1. Position the emitter where there will be a clear path to the 3D glasses.
2. Power on the TV, the 3D video device, and the 3D glasses.

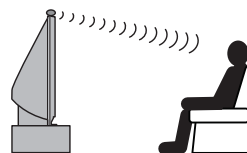

Note: The 3D video device must be powered on before the 3D Adapter can power on.

3. If the 3D Adapter does not power on automatically when you power on the 3D video device, press the **POWER** button.
4. If the **New Input Found** screen displays, assign a name to the input. If you have an 833 series TV, name the input **Game**.
5. Start video from the 3D video device and wait a few moments for an image to appear.
6. Enable the TV's 3D mode. For an 833 series TV, 3D settings are in the **FX Gaming** menu.
7. Select the Adapter's 3D mode. Press the **3D MODE** button to change.
 - For ordinary 2D signals, keep the Adapter powered on and use 3D Mode **Normal**.
 - For automatic detection of HDMI 1.4a 3D signals, use 3D Mode **Normal**.
 - For non-HDMI 1.4a 3D signals, press the **3D MODE** button repeatedly until the picture appears correct.

Picture Troubleshooting



*Blurry double image, checkerboard format. Turn on TV's 3D mode. Press **3D MODE** button to select 3D Mode Normal.*



*Two images, top-and-bottom format. Press **3D MODE** button to select 3D Mode for top/bottom.*



*Two images, side-by-side format. Press **3D MODE** button to select 3D Mode for side-by-side.*

Please check www.mitsubishi-tv.com for updates on 3D signals and safety.

3D Glasses

3D active LCD shutter glasses enable you to view 3D images when used with the matching IR emitter and a compatible 3D-ready TV.

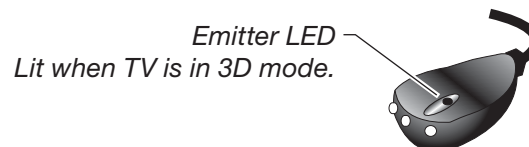
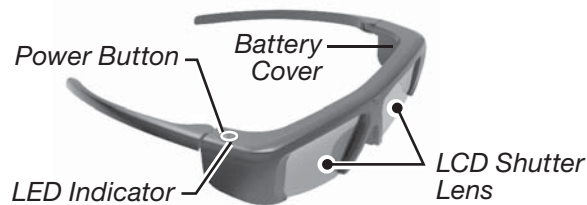

Battery Installation

- Each pair of glasses requires one CR2025 lithium battery.
- A continuously blinking red LED indicates low battery power. Install a new battery.
- See lithium-battery safety information at the front of this booklet.



Open the cover.



Remove the old battery if present.



Insert a new battery, positive (+) side facing out.



Close the cover.

For assistance call 1(800) 332-2119

Using the 3D Glasses

3D Glasses Operation

1. Turn on 3D Mode in the TV and 3D source device.
2. Press the **POWER** button on the glasses to turn on the glasses.
3. When the 3D program is complete, turn off 3D mode in the TV and 3D source device and turn off the glasses.

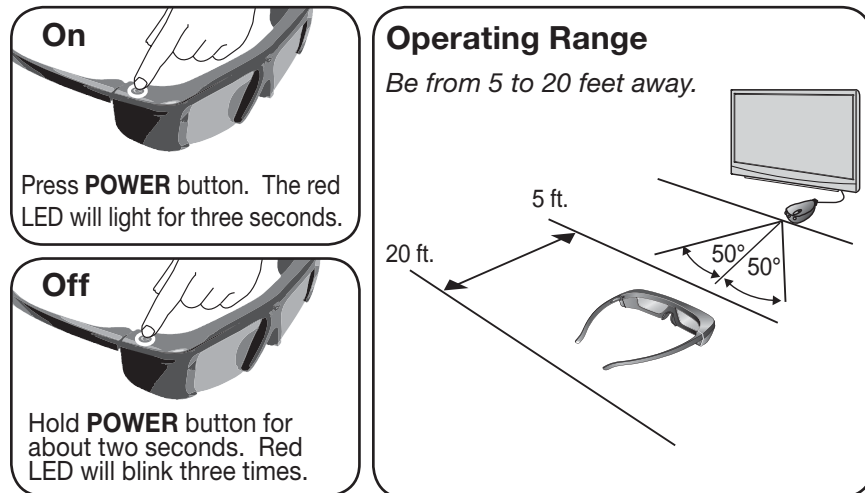

Notes On the 3D Glasses

- Shut off 3D glasses when not in use to extend battery life.
- Fluorescent and halogen lighting can cause the 3D glasses to flicker. Turn off these lamps if flickering occurs.
- Turning off the TV's 3D mode or changing the TV's input to a 2D input will turn off the IR emitter; the glasses will turn off automatically after two minutes.
- Moving out of range of the IR emitter for more than two minutes will cause the glasses to turn off automatically.
- Interference from other IR sources, such as motion detection devices, may cause the glasses to flicker or work intermittently. Turn off other IR source if interference occurs.
- The IR emitter in this system can also be used with Samsung 3D glasses model SSG-2100AB. Information about these glasses can be obtained from Samsung USA at www.samsung.com/usa/.
- You can also check www.mitsubishi-tv.com for any updates about compatible glasses.

Please check www.mitsubishi-tv.com for updates on 3D signals and safety.

Cleaning Instructions

- To avoid scratching the glasses, use only standard glasses lens cleaning cloth, microfiber cloth, or a soft non-scratching cloth such as cotton flannel. Make sure the cloth is clean and free of any foreign material that may scratch the glasses.
- Cloths pre-moistened with cleaning solutions designed specifically for eye glasses can be used, however, do not spray solutions directly on the glasses.
- DO NOT spray any cleaner directly onto the any surface of the glasses. This may result in fire, electric shock, damage to the product surface, or removal of control labels.
- DO NOT use chemicals containing alcohol, solvents, surfactants, wax, benzene, thinners, insect repellents, lubricants, or household cleaners. These may result in discoloration, removal of control labels, or cracks to the product surfaces.

Caution

- Do not place the product in a location exposed to direct sunlight, heat, fire, or water. This may result in product malfunction or fire.
- Do not apply force to the lenses of the 3D glasses. Do not drop or bend the product. This may result in product malfunction.

Troubleshooting

If you encounter . . .	Try this . . .
My 3D glasses do not operate	<ul style="list-style-type: none"> • Replace the battery if it is drained. • Focus your 3D glasses toward the TV front. Make sure that the distance from the TV to the glasses is less than 20 feet in a straight line. • Check if the emitter LED is lit. If not, make sure the TV's 3D mode is turned on and the emitter is plugged in.
The LED blinks continually.	The battery is drained. Replace it with a new one.

For assistance call 1(800) 332-2119

3D Safety Requirements

- 3D Glasses are NOT designed as sunglasses or safety glasses and do not provide protection. 3D glasses should be worn only when viewing 3D material.
- Do not wear the wireless glasses in any situations that require unimpaired visual perception.
- Children under the age of 5 should not view 3D programming.

Under normal conditions, 3D viewing is safe for your movies or games. Some people may experience discomfort, however. To minimize the potential for experiencing visual problems or any adverse symptoms:

- Read and follow any and all safety warnings that accompany your 3D glasses or 3D source devices.
- Maintain a distance of no less than 2 to 2.5 times the screen height measurement away from the display. Viewing from too short a distance can strain your eyes.
- Take regular breaks, at least 5 minutes after every hour of 3D viewing.

If you experience any of the following symptoms, discontinue 3D viewing until the symptoms go away:

- nausea, dizziness, or queasiness,
- headache, or eyestrain,
- blurry vision,
- double vision that lasts longer than a few seconds,

Do not engage in any potentially hazardous activity (for example, driving a vehicle) until your symptoms have completely gone away. If symptoms persist, discontinue use and do not resume 3D viewing without discussing your symptoms with a physician.

Do not use the glasses where loss of balance or limiting your field of vision may be dangerous to you.

Do not use near staircases, ledges or balconies. You may risk falling during or after use.

Epilepsy

WARNING! IF YOU OR ANY MEMBER OF YOUR FAMILY HAS A HISTORY OF EPILEPSY, CONSULT A PHYSICIAN BEFORE USING 3D VIDEO OR GAME PRODUCTS.

A small percentage of the population may experience epileptic seizures when viewing certain types of TV images or video games that contain flashing patterns of light.

The following people should consult a physician before viewing 3D Games or Video:

- Anyone with a history of epilepsy, or who has a family member with a history of epilepsy
- Anyone who has ever experienced epileptic seizures or sensory disturbances triggered by flashing light effects.

WARNING! SOME LIGHT PATTERNS MAY INDUCE SEIZURES IN PERSONS WITH NO PRIOR HISTORY OF EPILEPSY. DISCONTINUE 3D VIEWING IF YOU EXPERIENCE ANY OF THE FOLLOWING SYMPTOMS:

- Involuntary movements, eye or muscle twitching
- Muscle cramps
- Nausea, dizziness, or queasiness
- Convulsions
- Disorientation, confusion, or loss of awareness of your surroundings

Do not engage in any potentially hazardous activity (for example, driving a vehicle) until your symptoms have completely gone away.

Do not resume 3D viewing without discussing the symptoms with your physician.

Please check www.mitsubishi-tv.com for updates on 3D signals and safety.

**Mitsubishi Model 3DC-1000
3D Starter Kit Limited Warranty**

MITSUBISHI DIGITAL ELECTRONICS AMERICA, INC. ("MDEA") warrants as follows to the original purchaser of this 3D Starter Kit from an authorized MITSUBISHI Audio/Video Dealer, should the adapter, glasses, IR emitter, remote control or included accessories prove defective by reasons arising from improper workmanship and/or material:

- a. Length of Warranty. The Starter Kit including the 3D adapter, 3D glasses and IR emitter and all included parts, except for "consumable parts" such as batteries, are warranted for a period of one (1) year from the date of the original purchase at retail. We will repair or replace, at our option, any defective part without charge. Parts used for replacement may be replaced with those of like kind and quality and may be new or remanufactured. Parts used for replacement are warranted for the remainder of the original warranty period.
- b. Send In Service. MDEA provides send in service only. The owner is responsible for packaging the full kit or parts for repair safely and the shipping costs to the MDEA designated service location. MDEA will repair or replace and return the items without charge for return shipping.
- c. Notice. To obtain warranty service, you must notify Mitsubishi Digital Electronics America, Inc. of any defect within the applicable warranty time period. **BEFORE REQUESTING SERVICE**, please review the instruction booklet to insure proper installation and correct customer control adjustment. If the problem persists please arrange for warranty service.

1. TO OBTAIN WARRANTY SERVICE:

- a. Contact Mitsubishi Digital Electronics America, Inc. (MDEA) by calling 800-332-2119. The Consumer Relations Representative at this phone number will provide you with the details AND, when necessary, authorizations for the return of the kit or parts for repair. **DO NOT send the product or part for repair without the proper authorizations.**
- b. Proof of purchase date from an authorized MITSUBISHI dealer is required when requesting warranty service. Present your sales receipt or other document which establishes proof and date of purchase upon request by MDEA. THE RETURN OF THE OWNER REGISTRATION CARD IS NOT A CONDITION OF COVERAGE UNDER THIS LIMITED WARRANTY. However, please return the Owner Registration Card so that we can contact you should a question of safety arise which could affect you.

2. THIS LIMITED WARRANTY DOES NOT COVER:

- a. Consumable parts such as batteries, 3D Glasses and IR Emitters that were not sold as a part of the Starter Kit (refer to the instructions for the glasses and IR Emitter for warranty details), cosmetic damage or any other damage where such damage is caused by unauthorized modification, alteration, repairs to or service of the product by anyone other than an authorized MITSUBISHI

For assistance call 1(800) 332-2119

service center; physical abuse to or misuse of the product (including any failure to carry out any maintenance as described in the Owner's Guide or any product damaged by excessive physical or electrical stress); any products that have had a serial number or any part thereof altered, defaced or removed; product use in any manner contrary to the Owner's Guide; freight damage; or any damage caused by acts of God or other factors beyond the reasonable control of MDEA, such as power surge damage caused by electrical system or lightning. This limited warranty also excludes service where no defect in the product covered under this warranty is found, service related to unsatisfactory audio or visual reception or signal unless caused by a defect in the product that is covered under this limited warranty, all costs, expenses or any other damages arising from product installation, or set-ups, any adjustments of user controls (including contrast, brightness, color, tint, fine tuning, sharpness to the connected TV), other adjustment necessary to prepare the unit for display or use, connection with any external audio receiver, antenna, cable or satellite systems, or service of products purchased or serviced outside the U.S.A. Please consult the operating instructions contained in the Owner's Guide furnished with the product for information regarding user controls.

3. ANY EXPRESS WARRANTY NOT PROVIDED HEREIN, AND ANY REMEDY WHICH, BUT FOR THIS PROVISION, MIGHT ARISE BY IMPLICATION OR OPERATION OF LAW, IS HEREBY EXCLUDED AND DISCLAIMED. THE IMPLIED WARRANTIES OF MERCHANTABILITY AND OF FITNESS FOR ANY PARTICULAR PURPOSE ARE EXPRESSLY LIMITED TO A TERM OF ONE YEAR.

4. UNDER NO CIRCUMSTANCES SHALL MDEA BE LIABLE TO PURCHASER OR ANY OTHER PERSON FOR ANY INCIDENTAL, SPECIAL OR CONSEQUENTIAL DAMAGES, WHETHER ARISING OUT OF BREACH OF WARRANTY, BREACH OF CONTRACT, OR OTHERWISE.

5. Some states do not allow limitations on how long an implied warranty lasts, or the exclusion or limitation of incidental, special, or consequential damages, so the above limitations or exclusions may not apply to you.

6. This limited warranty gives you specific legal rights, and you may also have other rights which vary from state to state.



MITSUBISHI DIGITAL ELECTRONICS AMERICA, INC.
9351 Jeronimo Road
Irvine, CA 92618-1904

Please check www.mitsubishi-tv.com for updates on 3D signals and safety.

